

 **alamen**
treyleler



 [alamentreyler](#)

 [alamentreyler](#)

 www.alamen.com.tr

HAKKIMIZDA

Alamen Treyler 2004 yılında kurulmuş, öncelikle Orta Doğu ve Afrika'ya birçok ürün yaparak işe başlamış bir firmadır. Kurulduğundan bugüne 18 yılda yaklaşık 15.000 adet ürün ile adını en iyi üreticilerin arasına eklemiştir. Şu anda 60 personeli ile yıllık yaklaşık 400 adet yarı römork üretmektedir. Bugüne kadar 25 ülkeye ürün göndermiş olan firmamız bunlara her yıl yenilerini eklemektedir. Her yıl yaklaşık 20 adet yeni model çizimi yapıp müşterilerimizin isteklerini yerine getiriyoruz. Şu anda 10.000 m2 kapalı alana sahip olan fabrikamız. Ghana ülkesinde yeni yatırımını yapıp 2000 m2 lik üretim hattını devreye almıştır. Değişen üretim ve kalite ihtiyaçlarını sürekli olarak takip eden firmamız her yıl yeni makina yatırımları yapmaktadır. Alamen treyler olarak müşteri memnuniyeti ilk hedefimizdir. Bu misyon ile yola çıktık ve şu anda çalıştığımız müşterilerimizin birçoğu bizimle en az 10 yıl iş yapmış kişilerdir. Ürünlerimizi inceledikten sonra bizi aramayı ve fiyat almayı unutmayın.





































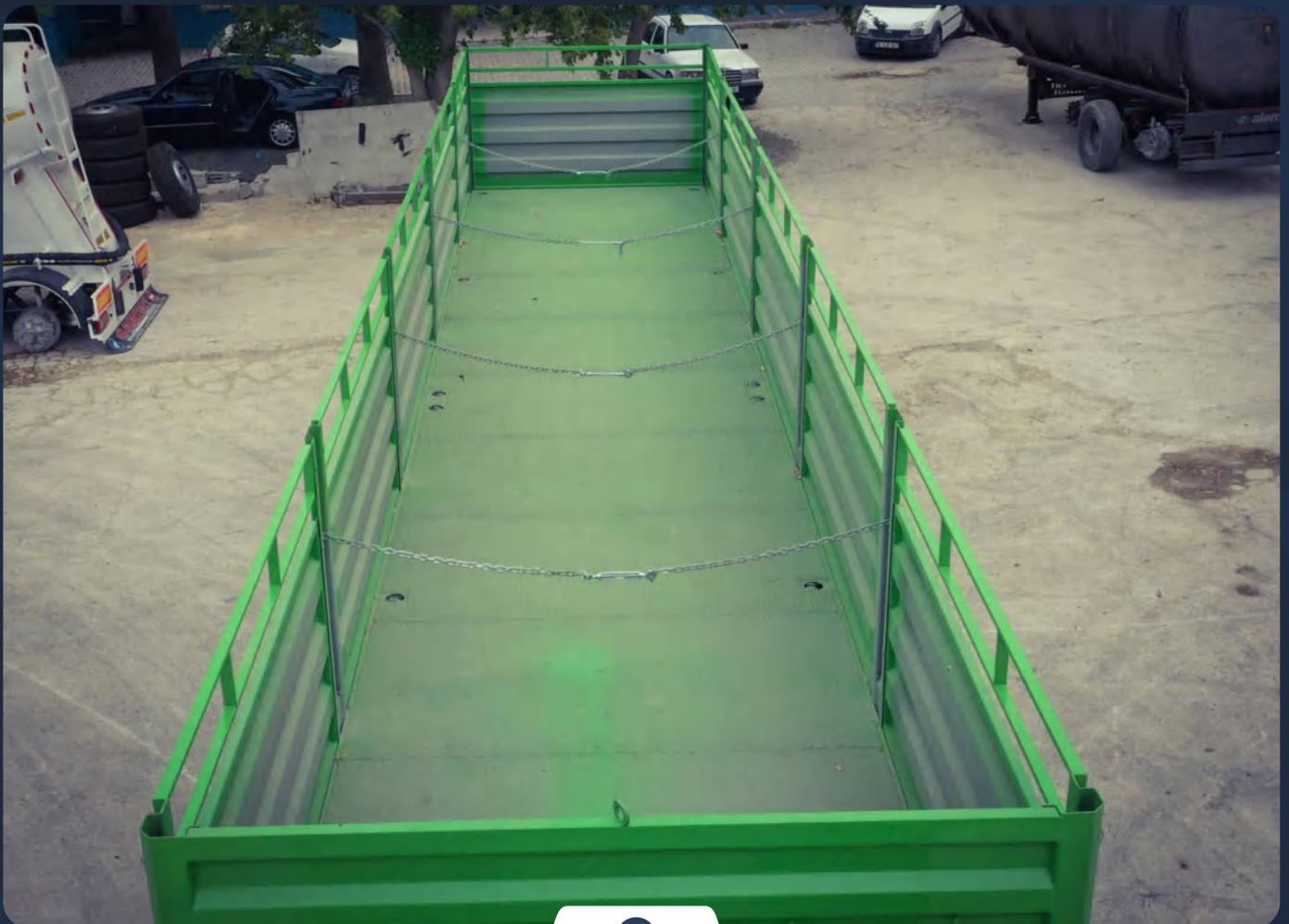

















































































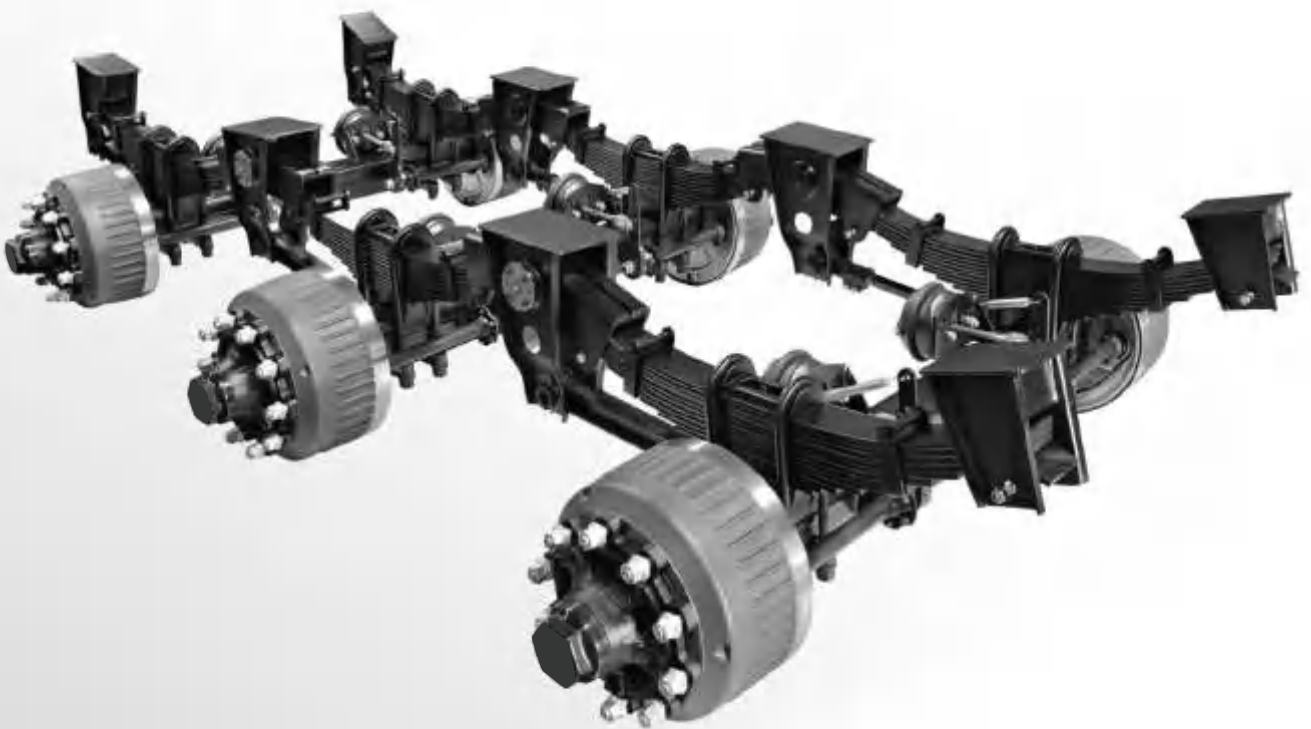

12-14-15-18 TON KAPASİTE TERS MAKAS DİNGİLİ

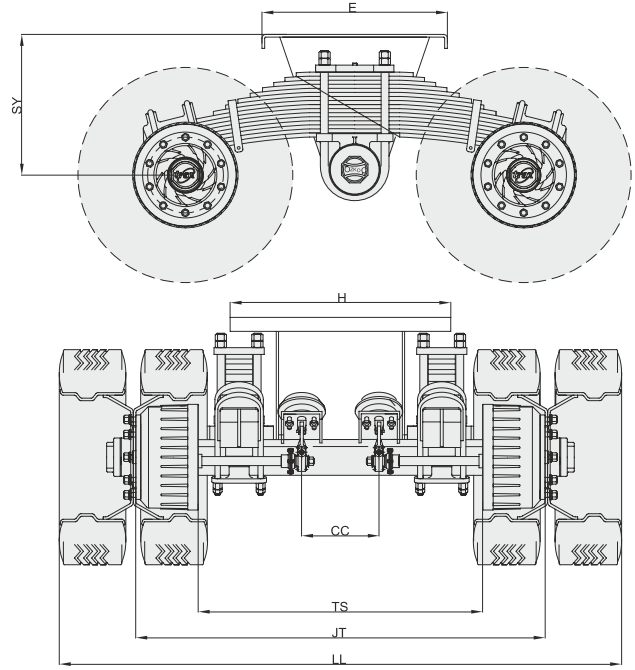
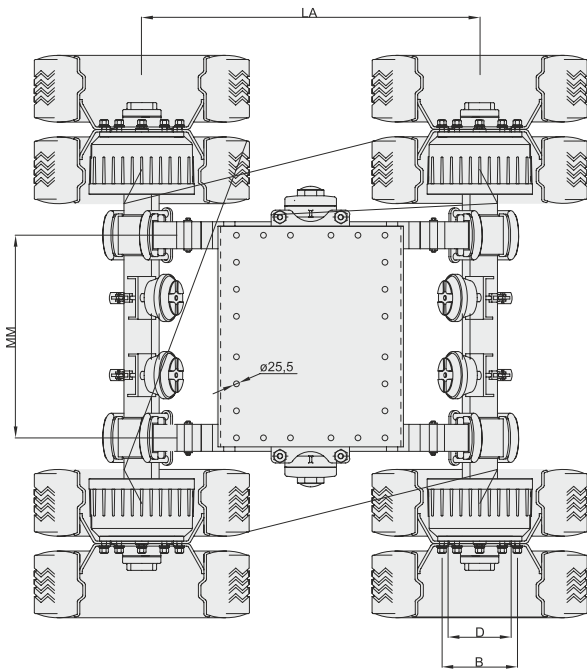
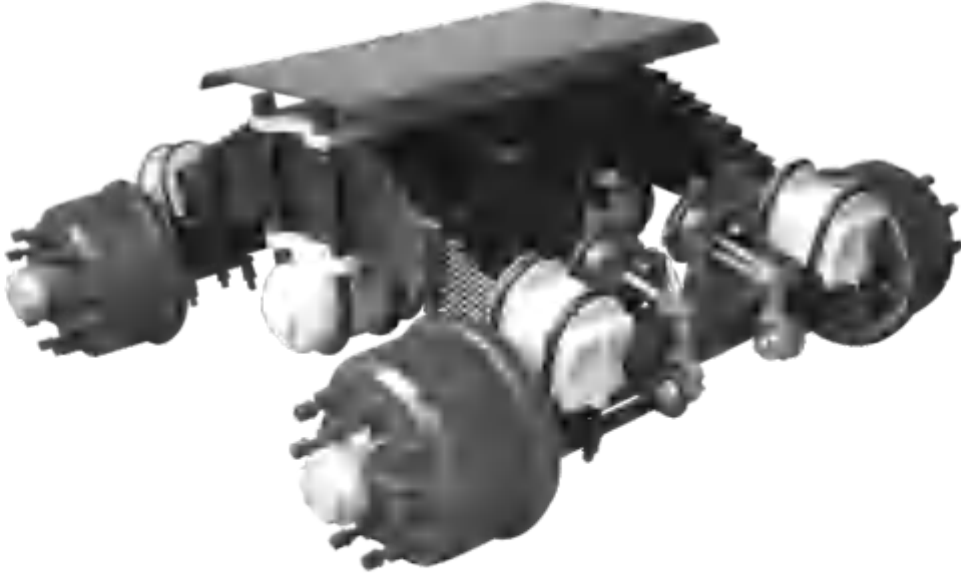

TYPE	CAPACITY	LL	JT	CC	TS	AA	BEARING	BRAKE	B/D	BOLT	MM	E/H	SY	LA	TYRE
3610	2*12000	2530	1850	368	1298	140*140	33213/218248	420*200	335/280.8	10*M22x1.5	900	800/980	625	1500	DOUBLE TYRE 22.5 RIM
3620	2*14000	2530	1850	368	1298	140*140	33215/33019	420*200	335/280.8	10*M22x1.5	900	800/980	625	1500	
3650	2*15000	2530	1850	359	1250	140*140	33215/32219	420*220	335/280.8	10*M22x1.5	900	800/980	625	1500	
3630	2*18000	2530	1850	306	1236	140*140	32314/32222	420*200	335/280.8	10*M22x1.5	900	800/980	625	1500	

"JT" ölçüsü isteğe bağlı değiştirilebilir. - If required, it is possible to modify the "JT" size.

HAVA SÜSPANSİYON SİSTEM | AIR SUSPENSION SYSTEM

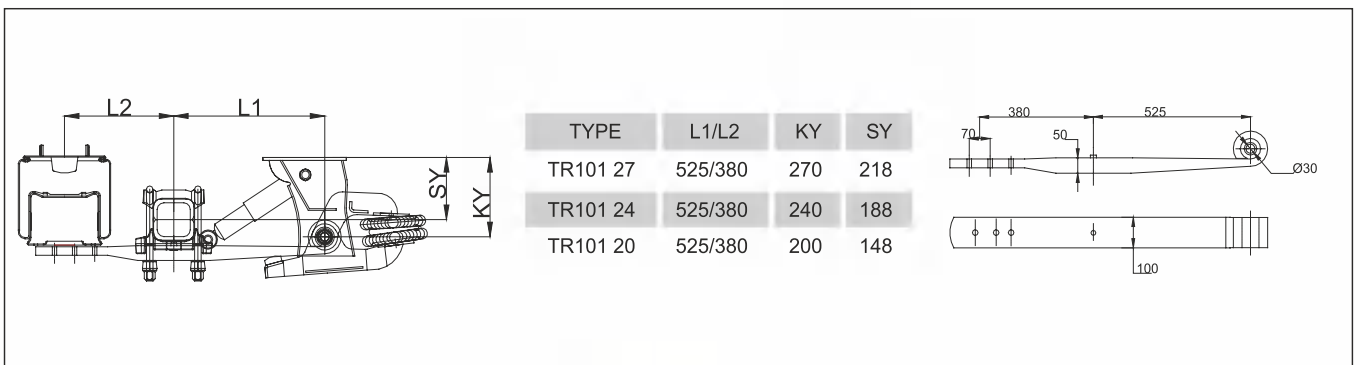
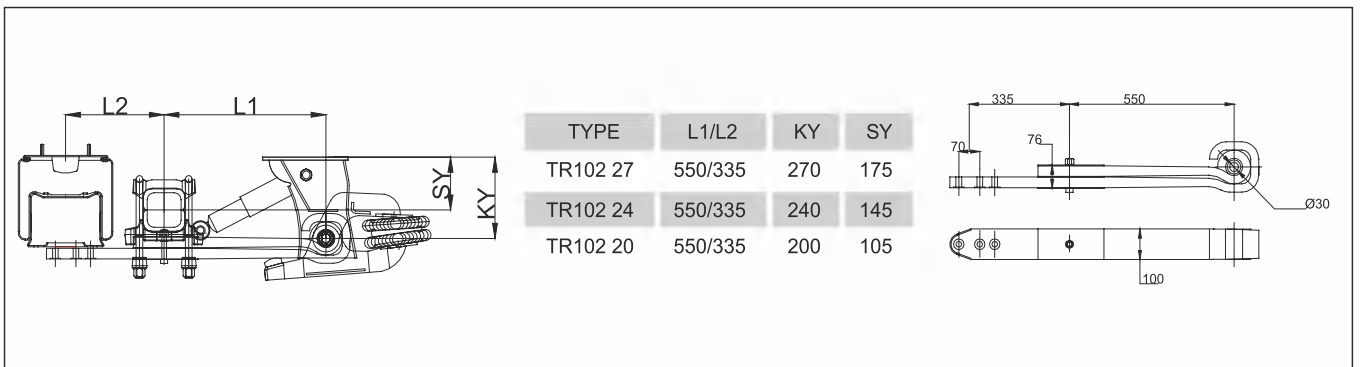
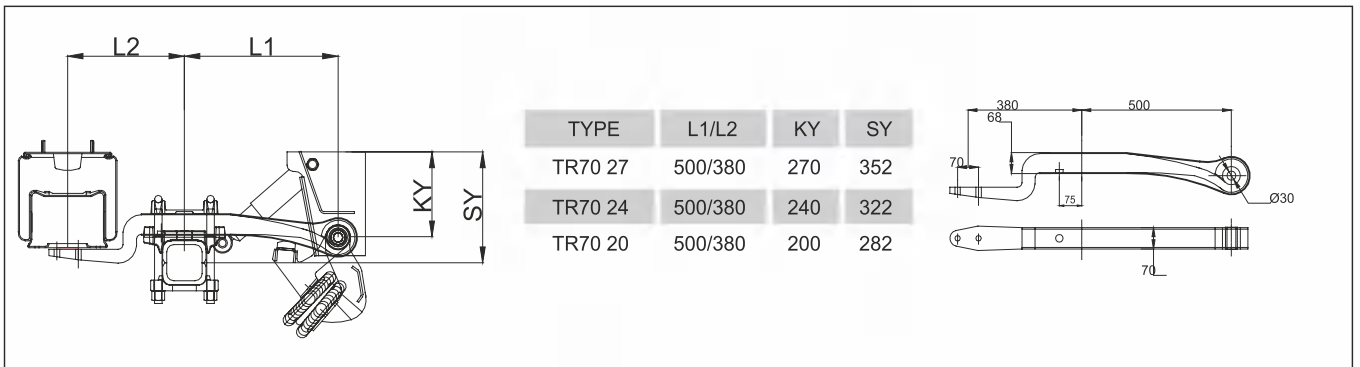
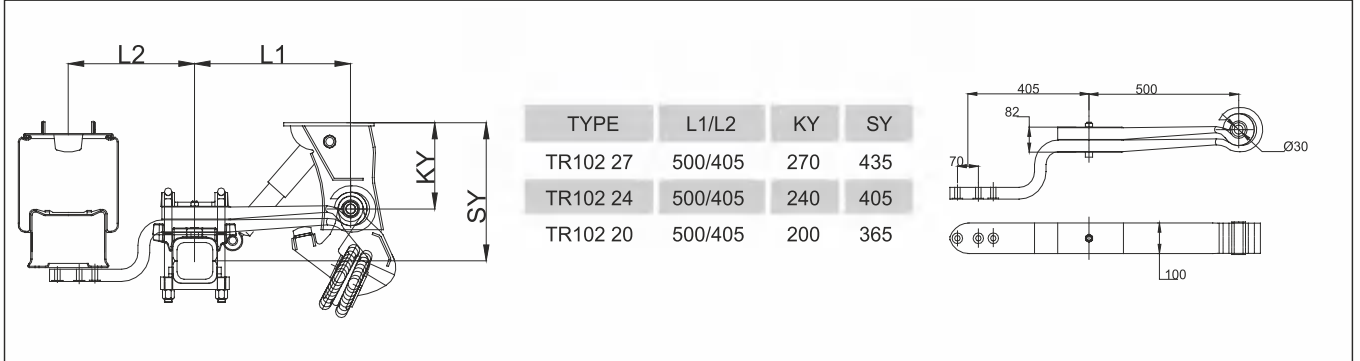

MEKANİK SÜSPANSİYON SİSTEM MECHANICAL SUSPENSION SYSTEM

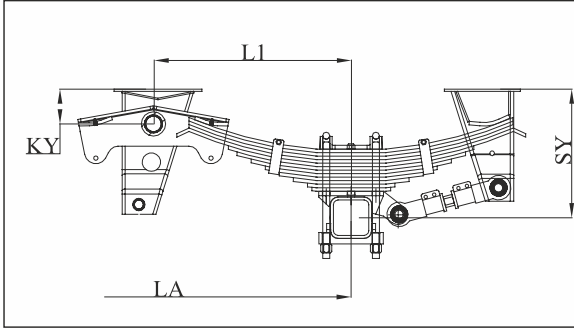

TYPE	L1	KY	SY	LA
TR110 135	675	120	415	1350
TR112 135	675	120	440	1350

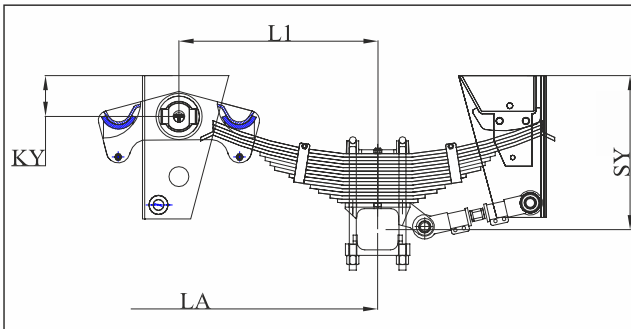

TYPE	L1	KY	SY	LA
TR114 136	680	140	525	1360
TR114 141	705	140	525	1410
TR114 150	750	140	525	1500
TR114 205	1025	140	525	2050

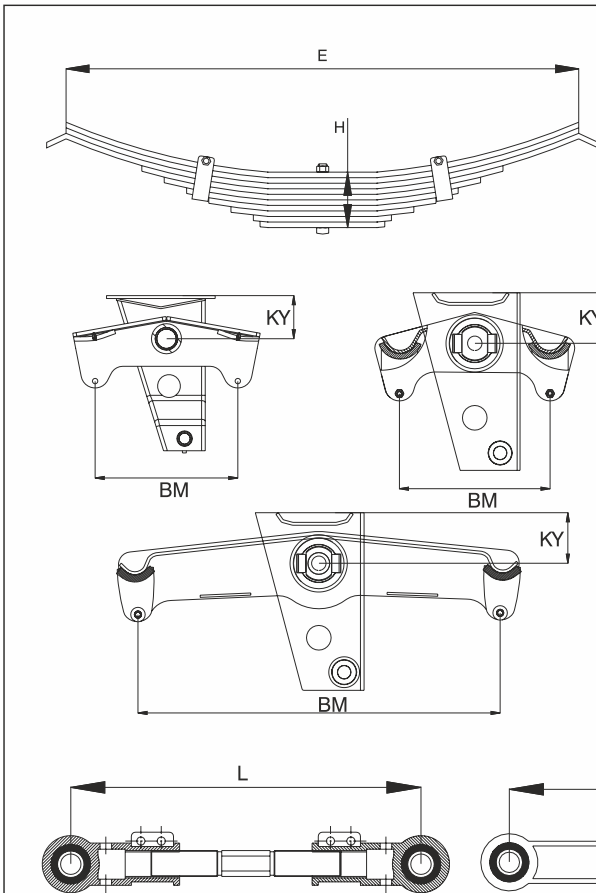

TYPE	LA	CAPACITY	E	H
TR3810	1350	12T-14T	1110	12*10 120
TR3811	1350	12T-14T	1110	12*12 144
TR3815	1360	14T-16T	1150	12*14 168
TR3816	1500	14T-16T	1300	12*14 168
TR3816	2050	12T-14T	1300	12*14 168

LA	CAPACITY	KY	BM
1350	12T-14T	120	395
1360	14T-16T	140	416
1500	14T-16T	140	416
2050	12T-14T	140	1000

LA	L	Ø
1350	360-465	30
1360	370-450	36
1500	425-515	36
2050	425-790	36

9.5-12 TON KAPASİTE TEK LASTİK DORSE DİNGİLİ (KAMPANALI) 9.5-12 TON CAPACITY SINGLE TYRE TRAILER AXLE (BRAKE DRUM)

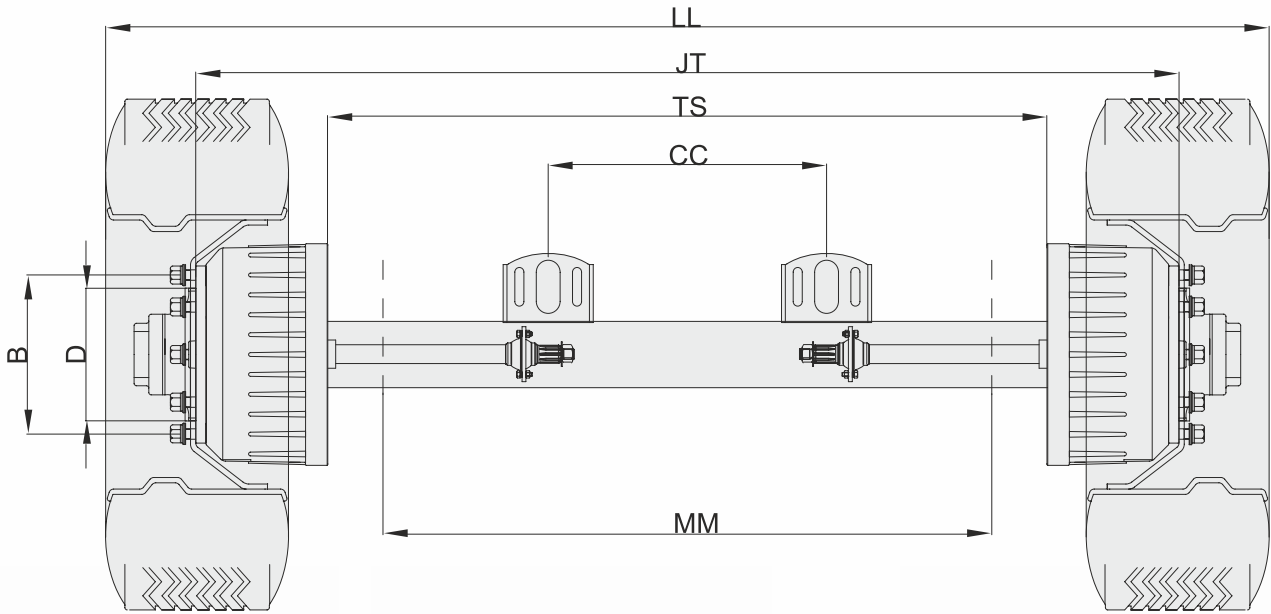

TYPE	CAPACITY	LL	JT	CC	TS	AA	BEARING	BRAKE	B/D	BOLT	MM	TYRE
1222	9500	2450	2070	588	1518	140*140	33213/218248	420*200	335/280.8	10*M22x1.5	1300	SINGLE TYRE
1220	12000	2450	2070	588	1518	140*140	33213/218248	420*200	335/280.8	10*M22x1.5	1300	22.5 RIM

"JT" ölçüsü isteğe bağlı değiştirilebilir. - If required, it is possible to modify the "JT" size.

9.5 12 TON KAPASİTE TEK LASTİK DORSE DİNGİLİ (DISK FREN) 9.5-12 TON CAPACITY SINGLE TYRE TRAILER AXLE (DISC BRAKE)

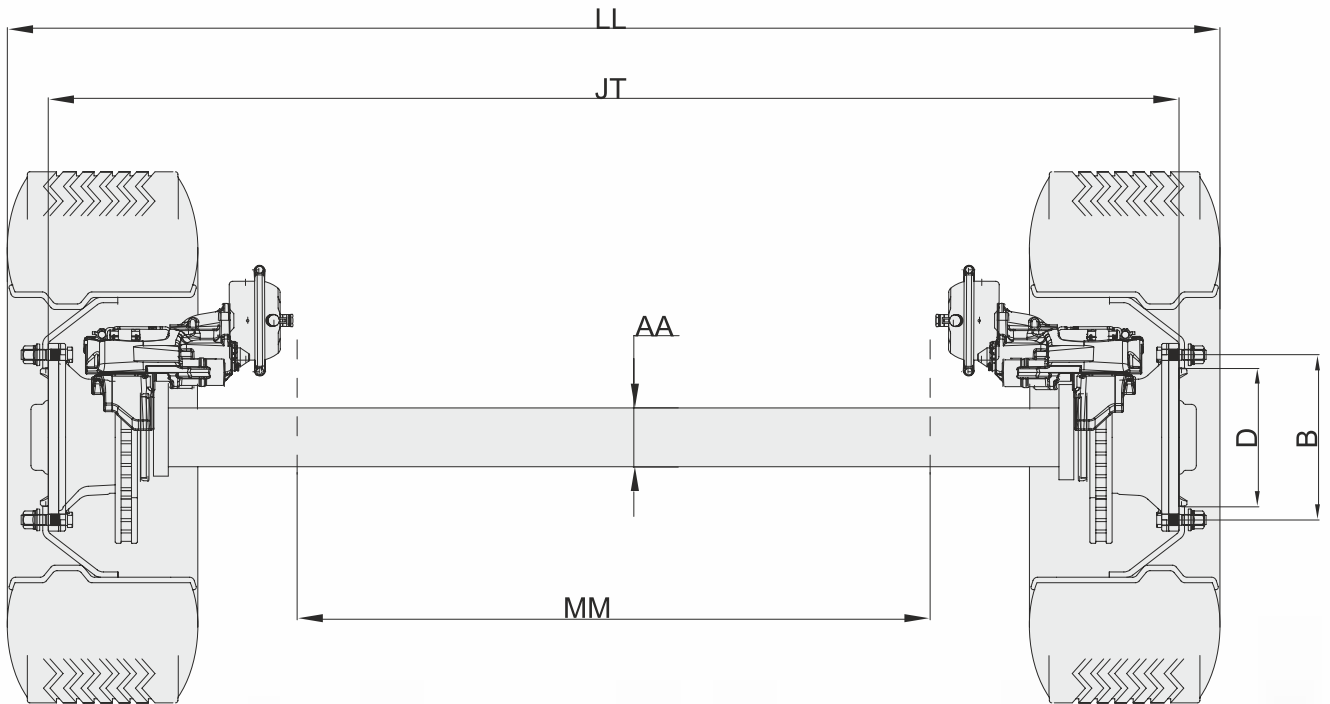

TYPE	CAPACITY	LL	JT	AA	BEARING	BRAKE	B/D	BOLT	MM	TYRE
1246	9500	2450	2290	140*140	33213/218248	420*200	335/280.8	10*M22x1.5	1300	SINGLE TYRE
1244	12000	2450	2290	140*140	33213/218248	420*200	335/280.8	10*M22x1.5	1300	22.5 RIM

"JT" ölçüsü isteğe bağlı değiştirilebilir. - If required, it is possible to modify the "JT" size.

12-14-15-18-20 TON KAPASİTE ÇİFT LASTİK LOWBED DİNGİLİ (KAMPANALI)
12-14-15-18-20 TON CAPACITY DOUBLE TYRE LOWBED AXLE (BRAKE DRUM)

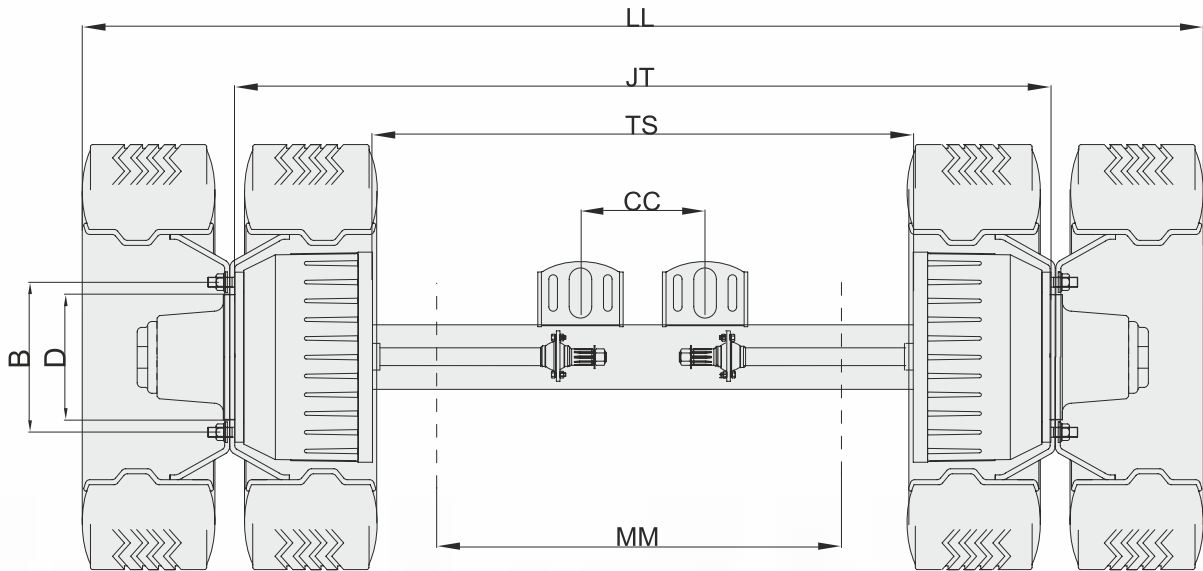

TYPE	CAPACITY	LL	JT	CC	TS	AA	BEARING	BRAKE	B/D	BOLT	MM	TYRE
3302	12000	3180	2500	1018	1948	140*140	33213/218248	420*200	335/280.8	10*M22x1.5	1600	DOUBLE TYRE
3300	14000	3180	2500	1018	1948	140*140	33215/33019	420*200	335/280.8	10*M22x1.5	1600	22.5 RIM
3350	15000	3180	2500	1009	1900	140*140	33215/32219	420*220	335/280.8	10*M22x1.5	1600	20 RIM
3330	18000	3180	2500	956	1885	140*140	32314/32222	420*200	335/280.8	10*M22x1.5	1600	
3340	20000	3180	2500	956	1885	145*145	32314/32222	420*200	335/280.8	10*M22x1.5	1600	

"JT" ölçüsü isteğe bağlı değiştirilebilir. - If required, it is possible to modify the "JT" size.

9.5-12 TON KAPASİTE ÇİFT LASTİK JUMBO DİNGİLİ (17.5-19.5 JANT)
9.5-12 TON CAPACITY DOUBLE TYRE JUMBO AXLE (17.5-19.5 RIM)

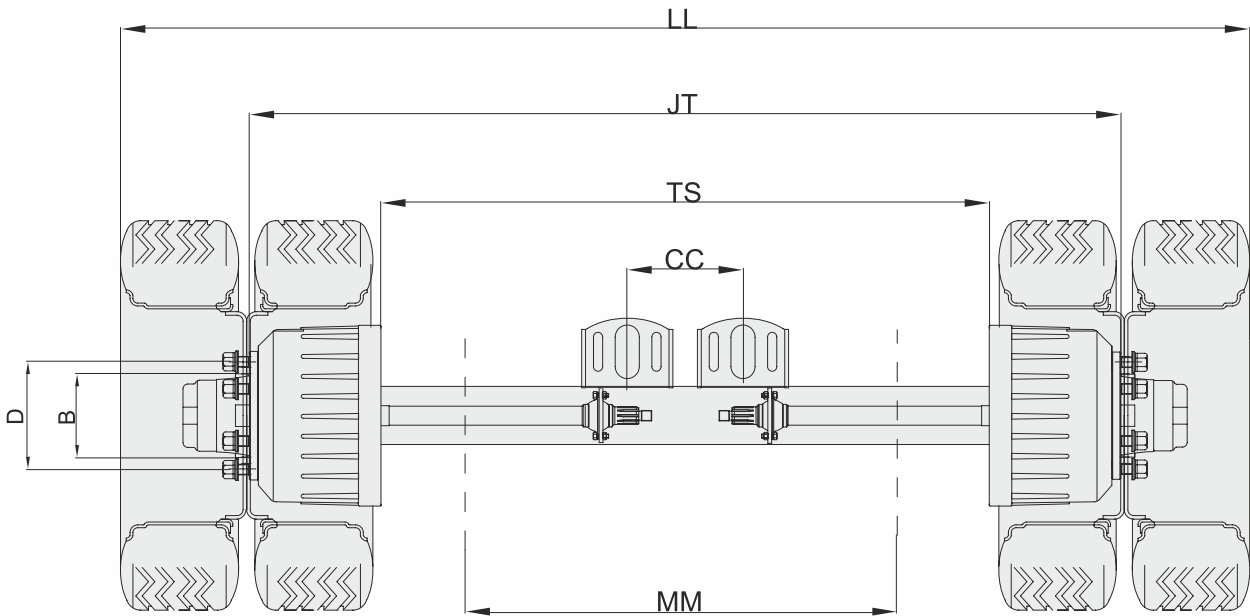

TYPE	CAPACITY	LL	JT	CC	TS	AA	BEARING	BRAKE	B/D	BOLT	MM	TYRE
5422	9500	2390	1850	265	1294	140*140	33213/218248	330*200	225/175.5	10*M22x1.5	900	DOUBLE TYRE
5440	12000	2840	2300	715	1744	140*140	33213/218248	330*200	225/175.5	10*M22x1.5	1440	19.5-17.5 RIM

"JT" ölçüsü isteğe bağlı değiştirilebilir. - If required, it is possible to modify the "JT" size.

PARÇA LİSTESİ / PART LIST

TERS MAKAS DİNGİL / TANDEM AXLE

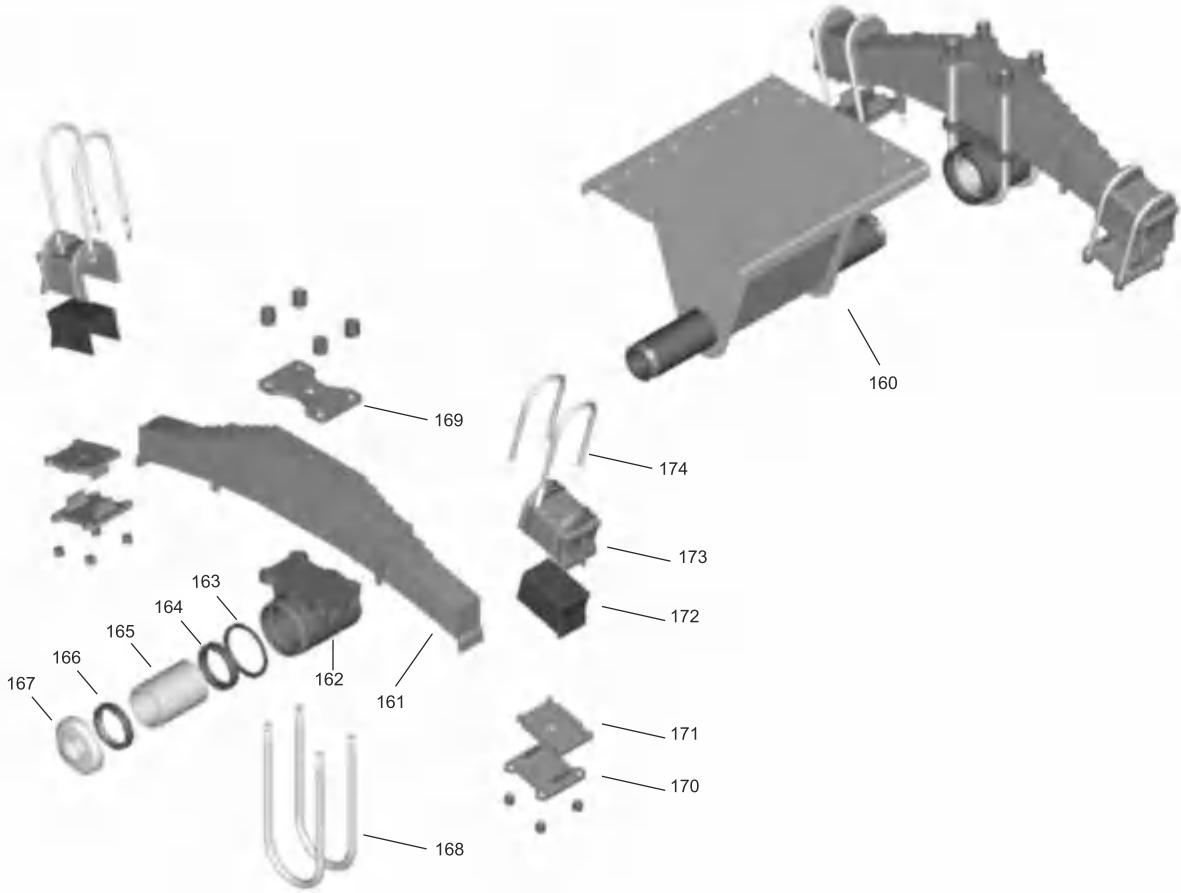

NO	ADI / DESCRIPTION	ADET / UNIT	STOK KODU/CODE
160	TANDEM / TANDEM	1	TR5042
161	MAKAS / LEAF SPRINGS	2	TR3818
162	TANDEM YATAK / TANDEM BED	2	TR6706
163	YAĞ KEÇESİ / OIL SEAL	2	TR7005
164	KEÇE YATAĞI / SEAL BED	2	TR99-2328
165	BURÇ / BUSHING	2	TR0726
166	TANDEM SOMUN / TANDEM NUT	2	TR5607
167	TANDEM KAPAK / TANDEM CAP	2	TR4706
168	TANDEM BAĞLANTISI / U BOLTS	4	TR1307
169	MAKAS ÜST KEP / SPRING PLATE	2	TR39104
170	ALT KEP / SPRING SEAT	4	TR39103
171	FREZELİ KEP / SPRING SEAT	4	TR39102
172	KEP LASTİĞİ / SPRING CUSHION	4	TR3505
173	ÜST KEP / SPRING TENSION CASING	4	TR39091
174	MAKAS BAĞLANTISI / U BOLTS	8	TR1305

PARÇA LİSTESİ / PART LIST

ANA KOVAN 22.5 JANT / AXLE BEAM 22.5 RIM

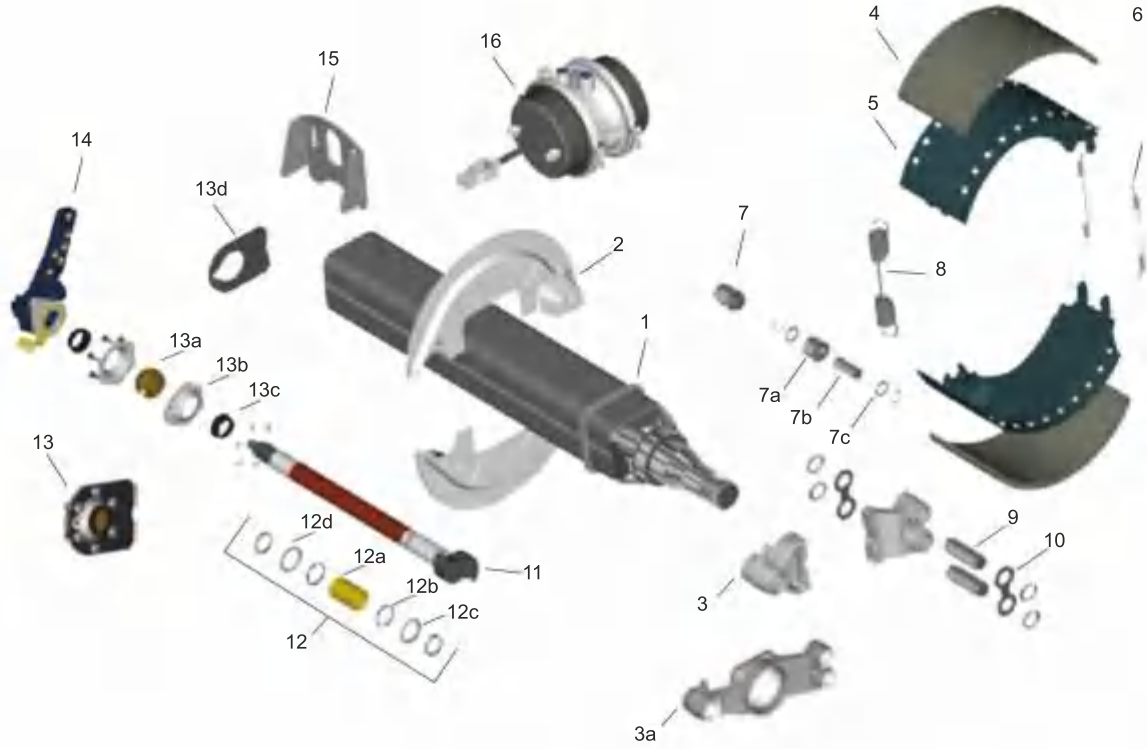

NO	ADI / DESCRIPTION	ADET / UNIT	STOK KODU / CODE	NO	ADI / DESCRIPTION	ADET / UNIT	STOK KODU / CODE
1	ANA KOVAN / AXLE BEAM ASSY	1	TR07	12	S KAM BURÇ SET / S CAM SHAFT BUSHING SET	2	TR5920
2	TOZ SACI / DUST COVER	2	TR6506	12A	BURÇ / BUSHING	2	TR0717
3	FRENAY / BRACKET ASSY	2	TR1511	12B	ORİNG / ORING	4	TR4107
3-A	FRENAY (BORU TİP) / BRACKET ASSY (TUBE TYPE)	2	TR1510	12C	ORİNG PULU DÜZ / ORING WASHER2		TR4803
4	BALATA / BRAKE LINING	1 SET	TR0511	12D	ORİNG PULU KADEMELİ / ORING WASHER CASCADE	2	TR4804
5	PABUÇ / BRAKE SHOE	4	TR1807	13	S KAM MİLİ YATAK SET / S CAM SHAFT SEAT SET	2	TR5909
6	KİLİT YAYI / LOCKING SPRING	4	TR7105	13A	BURÇ / BUSHING	2	TR0721
7	PABUÇ MAKARA SET / BRAKE SHOE BARREL SET	4	TR3610	13B	BOMBE SACI / CABER PLATE	4	TR5908
7A	MAKARA / BARREL	4	TR3604	13C	YATAK TOZ LASTİĞİ / SEAT DUST RUBBER	4	TR5907
7B	MAKARA PİMİ / BARREL PIN	4	TR3703	13D	S YATAĞI AYAĞI / S CAM SHAFT SEAT STAYS	2	TR5901
7C	MAKARA PULU / BARREL WASHER	8	TR4813	14	FREN CIRCIRI / SLACK ADJUSTER	2	TR1601
8	FREN YAYI / BRAKE SPRING	2	TR7106	15	FREN KÖRÜĞÜ AYAĞI / BRAKE CHAMBER STAYS	2	TR3201
9	PABUÇ PERNOSU / BRAKE SHOE PIN4		TR4327	16	FREN KÖRÜĞÜ / BRAKE CHAMBER	2	TR1728
10	PERNO KİLİDİ / PIN LOCK	2	TR4319				
11	S KAM MİLİ / S CAM SHAFT	2	TR5801-02				

Dizel Kompresör / Diesel Compressor / ضواغظ ديزل



TR	SERBEST HAVA GEÇİŞİ (DEBİSİ)	7200 lt/dak
	ÇALIŞMA BASINCI	2,5 – 3 Bar
	MOTOR	F4L912 Dizel ,1500 d/d,80 hp Beinei
	PİSTON ADEDİ VE ÇAPI	3 Adet – 160 mm
	PİSTON STROK	80 mm
	SOĞUTMA ŞEKLİ	Hava Soğutmalı

EN	FREE AIR PASS (FLOW RATE)	7200 liter/minute
	OPERATING PRESSURE	2,5 – 3 Bar
	ENGINE	F4L912 Diesel ,1500 d/d,80 hp Beinei
	NUMBE ROF PISTON AND DIAMETER	3 Pcs – 160 mm
	PISTONE STROKE	80 mm
	COLING TYPE	Air Cooled

AR	خروج الهواء الحر (التدفق)	7200 لتر / دقيقة
	ضغط الشغل "العمل"	3-2.5 بار
	المحرك	Beinei hp 80 ،d/d 1500 ديزل، F4912
	عدد وقطر المكبس	عدد 3 - 160 ملليمتر
	مكبس شوط المحرك	80 ملليمتر
	كيفية التبريد	تبريد هوائي

Dizel Kompresör / Diesel Compressor / ضواغظ ديزل



TR

SERBEST HAVA GEÇİŞİ (DEBİSİ)	10200 lt/dak
ÇALIŞMA BASINCI	2,5 – 3 Bar
MOTOR	F4L912 Dizel , 1500 d/d, 80 hp Beinei
PİSTON ADEDİ VE ÇAPI	2 Adet – 220 mm
PİSTON STROK	90 mm
SOĞUTMA ŞEKLİ	Hava Soğutmalı

EN

FREE AIR PASS (FLOW RATE)	10200 liter/minute
OPERATING PRESSURE	2,5 – 3 Bar
ENGINE	F4L912 Diesel, 1500 d / d, 80 hp Beinei
NUMBE ROF PISTON AND DIAMETER	2 Pcs- 220 mm
PISTONE STROKE	90 mm
COLING TYPE	Air Cooled

AR

10200 لتر / دقيقة	خروج الهواء الحر (التدفق)
3-2.5 بار	ضغط الشغل "العمل"
Beinei hp 80 ، d/d 1500 ديزل، F4912	المحرك
عدد 2 – 220 ملليمتر	عدد وقطر المكبس
90 ملليمتر	مكبس شوط المحرك
تبريد هوائي	كيفية التبريد

Elektrikli Kompresör / Electric Compressor / ضواغظ كهربائية/المواصفات التقنية



TR

SERBEST HAVA GEÇİŞİ (DEBİSİ)	7200 lt/dak
ÇALIŞMA BASINCI	2,5 – 3 Bar
MOTOR	18,5 Kw 1500 d/d elektrik motor
PİSTON ADEDİ VE ÇAPI	3 Adet – 160 mm
PİSTON STROK	80 mm
SOĞUTMA ŞEKLİ	Hava Soğutmalı

EN

FREE AIR PASS (FLOW RATE)	7200 lt/dak
OPERATING PRESSURE	2,5 – 3 Bar
ENGINE	18,5 Kw 1500 d/d elektrik motor
NUMBE ROF PISTON AND DIAMETER	3 Adet – 160 mm
PISTONE STROKE	80 mm
COLING TYPE	Hava Soğutmalı

AR

خروج الهواء الحر (التدفق)	7200 لتر/ دقيقة
ضغط الشغل "العمل"	3-2.5 بار
المحرك	محرك كهربائي, 18,5 kw, 1500 d/d
عدد وقطر المكبس	عدد 3 - 160 ملليمتر
مكبس شوط المحرك	80 ملليمتر
كيفية التبريد	تبريد هوائي

Elektrikli Kompresör / Electric Compressor / ضواغظ كهربائية/المواصفات التقنية

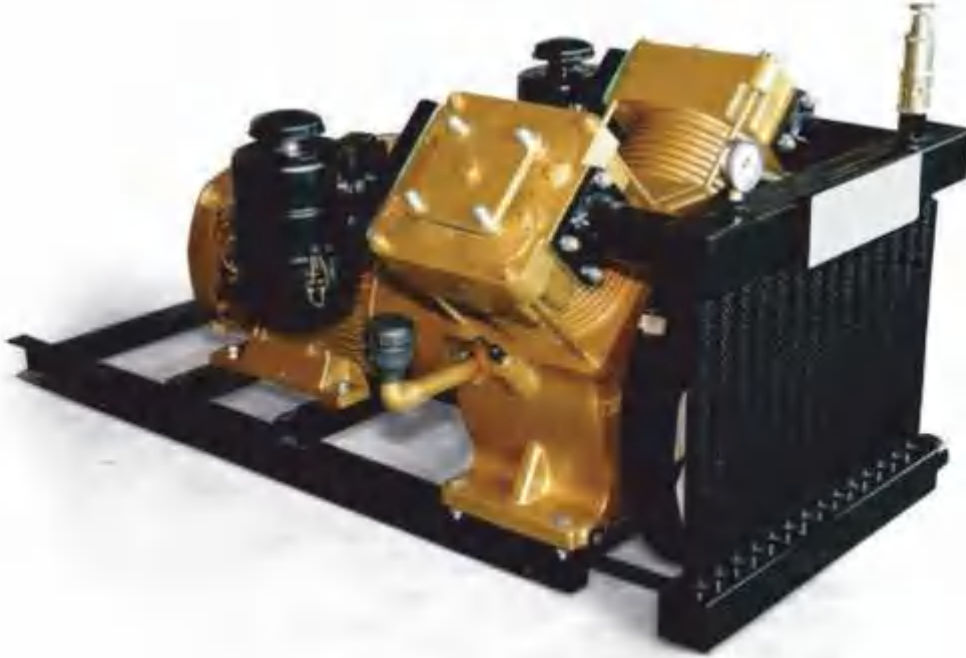

TR

SERBEST HAVA GEÇİŞİ (DEBİSİ)	10200 lt/dak
ÇALIŞMA BASINCI	2,5 – 3 Bar
MOTOR	22 Kw ve 30 Kw 1500 d/d elektrik motor
PİSTON ADEDİ VE ÇAPI	2 Adet – 220 mm
PİSTON STROK	90 mm
SOĞUTMA ŞEKLİ	Hava Soğutmalı

EN

FREE AIR PASS (FLOW RATE)	10200 liter/minute
OPERATING PRESSURE	2,5 – 3 Bar
ENGINE	22 Kw and 30 Kw 1500 d/d electric motor
NUMBE ROF PISTON AND DIAMETER	2 Pcs - 220 mm
PISTONE STROKE	90 mm
COLING TYPE	Air Cooled

AR

خروج الهواء الحر (التدفق)	10200 لتر/ دقيقة
ضغط الشغل "العمل"	3-2.5 بار
المحرك	محرك كهربائي, 22 Kw و 30 kw 1500 d/d
عدد وقطر المكبس	عدد 2 – 220 ملليمتر
مكبس شوط المحرك	90 ملليمتر
كيفية التبريد	تبريد هوائي



alamen

Alamen Treylar San. ve Tic. Ltd. Őti.

Derince Mahallesi Paymar Caddesi No: 30/A Antakya / Hatay

Tel: +90326 267 3311 Fax: +90326 267 3377 Mobil: +90531 468 8888

Email: info@alamen.com.tr - alamentrailer@hotmail.com
salimkapi@hotmail.com
